

# Freedom bathtubs



**RAVAK**<sup>®</sup>

FREEDOM  
IS A STATE  
OF MIND

Freedom O



**Freedom R**



**Freedom O**

169 x 80 cm



**Freedom R**  
175 x 75 cm



MAIN  
SALES

# ARGUMENTS

**1** Freestanding bathtub.  
Do not limit yourself just relax.

# Main sales arguments

2 Set the bathtub in space and pick the side which offers a better view

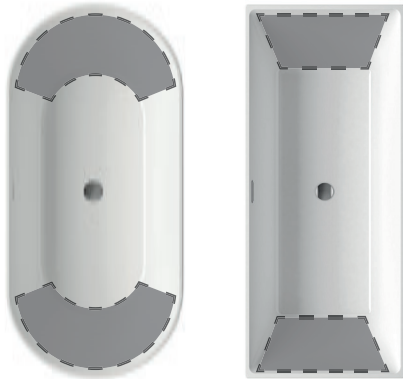

3 Design unit with a freestanding bathtub



4 Freedom to bathe alone or together



5 Bathtub Freedom – no cladding or box detail required



6 Simple installation – bath base supports are preinstalled

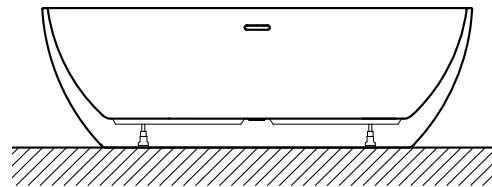

7 Easy to move due to lightweight acrylic construction

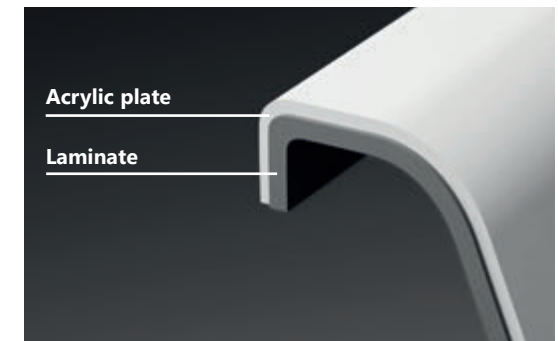

# WHY BUY A FREE STANDING BATH?

## Design

1 Worldwide trend in modern bathrooms.  
One of the most popular bathtubs.

2 Improves the image of the  
selling point.

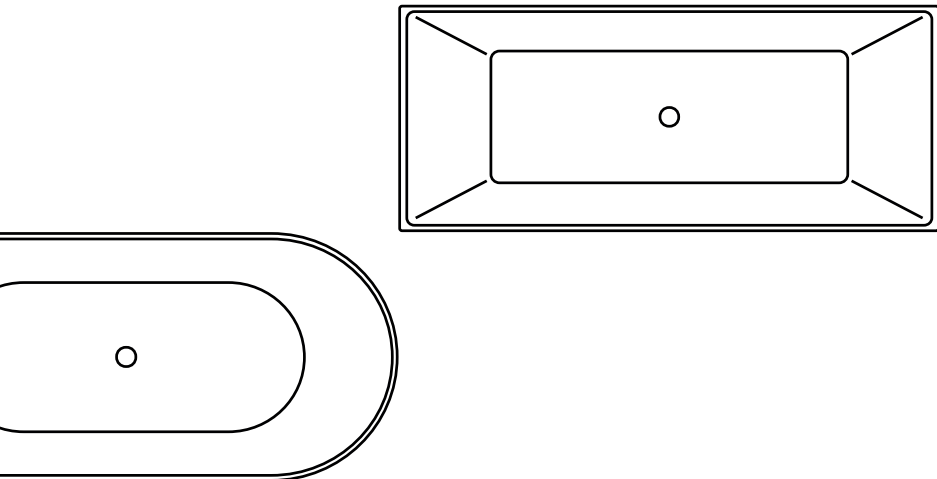

## Sales & Profits

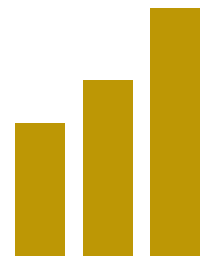



Why buy A FREE  
STANDING BATH?

\*\*\*\*\*

# Premium & positioning

3

Higher positioning brings  
more profit.



# RAVAK

# WORLDWIDE



More than:

**10.000.000** satisfied customers

**10.000** shops

**50** countries around the world

# REFERENCES

Clients around the world enjoy the benefits of a RAVAK bathroom solution.

Like water, our products aren't limited by borders. That's why you can find them in more than fifty countries worldwide, placed in some of the finest hotels, companies and private homes. Everywhere, our customers appreciate our brand, its quality and original design.



# DESIGNERS

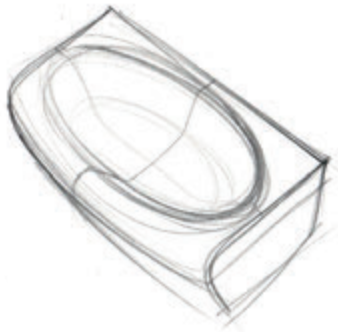

## Kryštof Nosál

Founder of the Nosal Design studio.

A top Czech product designer. His motto is to provide a simple, yet functional solution with a clear idea. Formerly designer for Narex and other international companies, he has crafted many of the most popular RAVAK bathroom products. He is a regular nominee of the prestigious design competitions.



reddot design award  
winner 2015



DESIGN  
AWARD  
2016

# DESIGNERS



## **Achim Storz**

Founder of the Design Storz studio.

When designing our baths, studio Storz draws on the tradition of automotive interiors designed for Porsche, BMW and Audi, as well as consumer goods, such as Adidas, Hugo Boss and Colgate. Achim Storz provides our products with the author's genuine imprint and precise solutions.

# RAVAK TECHNOLOGY



Pressworking of acrylic moulding for future bathtub – vertical heating technology.



Acrylic moulding RAVAK

All surface finishes are done in our electroplating and paint lines.



Electroplating RAVAK

An environmentally friendly electrostatic powder painting on aluminium shower enclosure frames.



Paint line RAVAK

A revolutionary technology creates an invisible protective layer over the surface of the water-repelling glass.

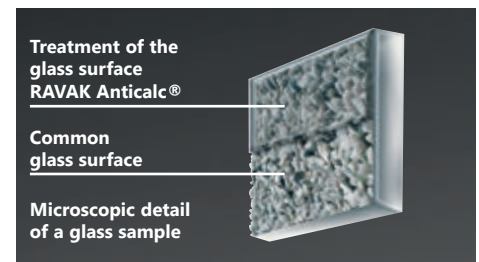

RAVAK AntiCalc®

# RAVAK MATERIALS

A mixture of ground dolomite and resin is used to produce wash basins and shower trays.



Cast Marble

Highly effective reinforcement for acrylic products with polyester resin and glass fibre.



Fibreglass

Exclusive technology for reinforced acrylic baths with polyurethane foam, patented by RAVAK.

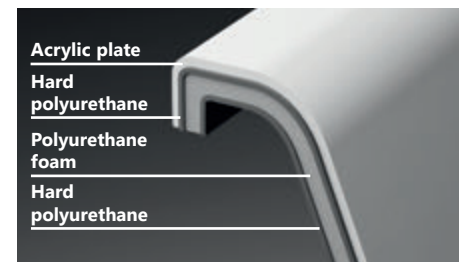

PU Plus

Bathroom furniture is made of quality AMT Chipboard (Anti-moisture treated), accompanied with high-quality moisture impregnation.



AMT Chipboard

# MERCHANDISING



We design displays.  
We organize quality training sessions.

Example of a good display of RAVAK products.



# PRODUCT SUPPORT

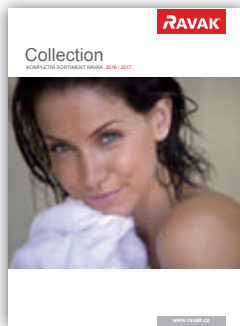

Catalogues



Specialised catalogues

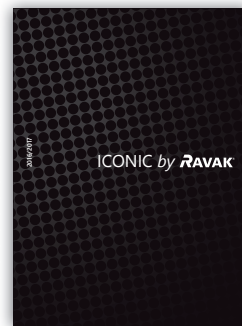

Posters

RAVAK a.s.  
Obecnická 285, 261 01 Příbram 1  
Czech Republic  
tel.: +420 318 427 111, +420 318 427 200  
fax: +420 318 427 269, +420 318 427 278  
info@ravak.cz  
www.ravak.com  
www.ravak.cz

The logo consists of the word "RAVAK" in a bold, white, sans-serif font, with a registered trademark symbol (®) to the upper right of the letter "K". The text is centered within a solid red rectangular background.